



Analytical Industries Inc. dba Advanced Instruments Inc. provides gas analysis solutions through advanced sensor and analyzer technology. Performance, quality, value and world class customer service has made **AII** a global leader in supplying solutions to the process instrumentation, natural gas, diving and medical industries. Products are manufactured under a single, independently certified quality system that complies with ISO 9001:2000 and major international standards.



## Oxygen Analysis below 1 PPB

Featuring the innovative Pico-Ion™ UHP series oxygen sensor and easy to use menu driven controls, the GPR-1600 UHP provides a high performance, no maintenance solution for oxygen analysis below 1 ppb at a reasonable price.

With an accuracy of  $\pm 1\%$  FS, sensitivity of 0.5% FS, .995 linearity across 4 standard ranges and auto-calibration capability with remote access, this fully equipped analyzer with its 316L VCR and orbitally welded sample system provide users with the highest ROI possible. This analyzer goes into standby mode, to protect the sensor, automatically if the power supply is interrupted.

## Process Oxygen Analyzers

Advanced sensor technology is evident across the widest range of oxygen analyzers available today. The GPR-1600MS featuring the innovative Pico-Ion MS Series sensor analyzes O<sub>2</sub> from 10 PPB to 1000 PPM; the GPR-1600 from 100 PPB to 1% with air calibration capability; the GPR-2600 from 0.05% or 500 PPM to just under 100%; the GPR-3100 is the only electrochemical sensor based oxygen purity analyzer with 24 month sensor life in 100% O<sub>2</sub>.

Sharing a common platform, SS wetted parts, an accuracy of  $\pm 1\%$  FS, sensitivity of 0.5% FS, .995 linearity across 4 standard ranges and auto-calibration capability with optional sample, span, zero inlet valves, these analyzers are individually optimized. The PPB and purity analyzers include a unique CSA/CE approved heater system for added stability; PPM and PPM analyzers feature fast response long life sensors and a bypass sample system which significantly increase productivity; a proprietary sensor specific compatible with up to 100% CO<sub>2</sub> further extends the application range.



## ATEX Certified Explosion Proof Oxygen Analyzers

Sharing a common platform, stainless steel wetted parts, flame arrestors, an accuracy of  $\pm 1\%$  FS, sensitivity of 0.5% FS, .995 linearity across 4 standard ranges with long life no maintenance sensors, the GPR-18MS, GPR-18 and GPR-28 analyzers offer users a choice of PPB, PPM and percentage range oxygen analysis in hazardous areas containing hydrogen EEx d IIB+H<sub>2</sub> T5 or lesser flammables, such as ethylene, and dust.

A unique heater system for added stability is optional as are custom designed sample conditioning systems. This platform also includes the proprietary sensor designed specifically for gas streams containing up to 100% CO<sub>2</sub> which further extends the application range.

## Applying the Sensor Technology

The same high performance oxygen sensors employed by the full featured Process Oxygen Analyzers above are available in several additional configurations tailored to specific applications.



## Natural Gas

The proprietary CO<sub>2</sub> compatible sensor; intrinsically safe design; alarms (AIS) or loop power (IS); modular sample system to remove H<sub>2</sub>S, water and regulate inlet pressure make the GPR-1500 and GPR-2500 the preferred PPM and percent O<sub>2</sub> analyzers for vacuum extraction and transmission.



## Portable Analyzers

The GPR-1200 Series PPB, PPM analyzer (left) employs the process bypass sample system to justify its purchase on increased productivity alone; the GPR-2000 provides percent measurements; the GPR-3500MO is easy to use and the most accurate portable analyzer for oxygen purity analysis.



## 2 Wire 4-20 Transmitters

Advanced sensors coupled with basic electronics make the GPR-1500 and GPR-2500 (which can be configured for process, ambient and purity analysis) the most compact and economical PPM and percent analyzers available.



## Proprietary Sensor Technology

Often overlooked is the fact that the heart of any analyzer is the sensor. Thus advancing the sensor technology is a critical element in the development of analyzers. Analytical Industries Inc. focuses on optimizing the critical characteristics of the sensor for specific application and has produced the first real advancements in sensor technology in decades.

All sensors are manufactured under an independently certified QA system that complies with ISO 9001:2000, FDA, European and Canadian standards.

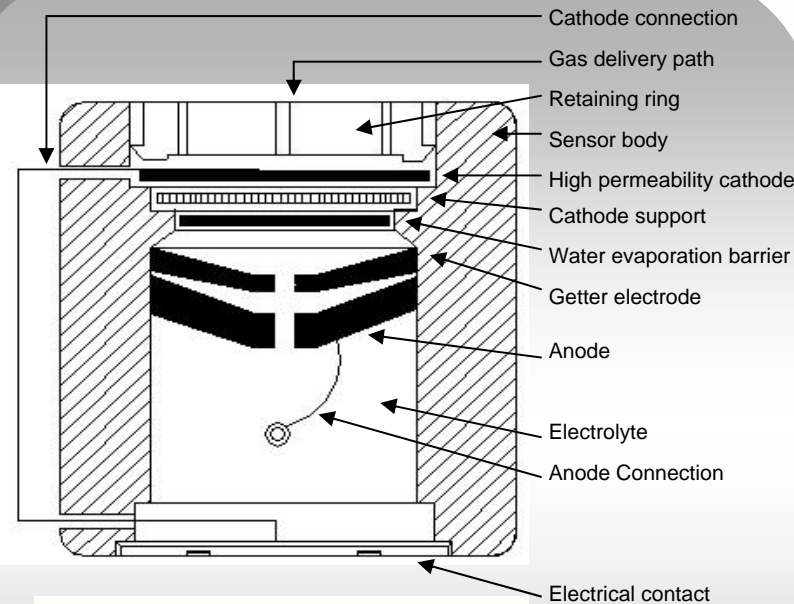

**Pico-Ion™ ppb Oxygen Sensor**

### Advancements:

Signal output 100x > traditional sensors  
High signal to noise ratio  
Maximize the rate oxygen is reacted  
Compact disposable design  
Transportable, insensitive to minor shock  
Low cost of ownership

### Performance:

Lower detectable limit < 1 ppb  
Accuracy and repeatability < ±1%  
Stability 6 months < 5% drift  
Recovers faster from exposure to O<sub>2</sub>  
Service life 15 months  
No sensor maintenance

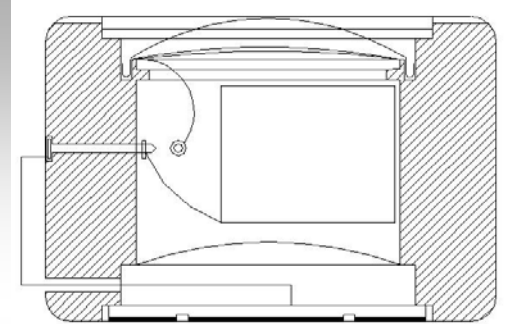

**Galvanic ppm Oxygen Sensor**

### Advancements:

Signal output 2x higher  
Innovative design, materials  
Proprietary mfg process  
Insensitive to vibration  
Retain compact design  
Low cost of ownership

### Performance:

Accuracy < ± 1% FS  
Sensitivity 0.5% FS (50 ppm)  
Service life 24 mos < 100 ppm  
Recovery air to 10 ppm < 1 hr.  
Op temp -20°C in 0-100% CO<sub>2</sub>  
No sensor maintenance

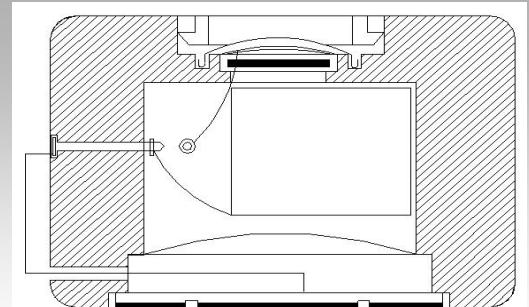

**Galvanic Oxygen Purity Sensor**

### Advancements:

Stability in pure oxygen  
Maintain O<sub>2</sub> reaction, signal  
Suppressed range capability  
Insensitive to vibration  
Retain compact design  
Low cost of ownership

### Performance:

Accuracy < ± 1% FS  
Accuracy 0.1% following cal  
Service life 24 mos 100% O<sub>2</sub>  
Stability 30 days < 1% drift  
Sensitivity, resolution 000.00  
No sensor maintenance

**Galvanic % Oxygen Sensor**

### Advancements:

Innovative design, materials  
Control O<sub>2</sub> reaction  
Proprietary mfg process  
Insensitive to vibration  
Retain compact design  
Low cost of ownership

### Performance:

Accuracy < ± 1% FS  
Sensitivity 0.5% FS (500 ppm)  
Service life up to 10 yrs in air  
Op temp -40°C in 0-100% CO<sub>2</sub>  
Linear pressure comp to 10 atm  
No sensor maintenance

## Competitive Replacement Sensors

Differences in sensor signal output prevents updating competitive analyzers with all the benefits our advanced sensor technology. Common cross references follow (contact the factory for a complete listing):

<b>AII Sensor:</b>	<b>Competitor:</b>	<b>Sensor Model:</b>	<b>Analyzer Model:</b>
PSR-12-223	Teledyne GE Panametrics	B2C, B2, S2, Z2 OX-1	3000T, 316RA, 311 O2X-1 Transmitter
PSR-12-223-L	Teledyne	L2, L2C	3000T, 3010T, 3020T
XLT-12-123	Teledyne GE Panametrics	A2C, A2 OX-2	3000T, 316RA, 311 O2X-1 Transmitter
PSR-11-21 / 23	Teledyne GE Panametrics	B1, B1C / B3, B3C OX-3	3000P, 326RA 320's O2X-1 Transmitter
XLT-11-15	Teledyne GE Panametrics	A3 and/or A5 OX-4	3000P, 326RA 320's O2X-1 Transmitter

### Contact the factory to explore:

Application needs and custom sample systems, analyzer retrofits and trade-in possibilities, OEM opportunities